

HEAVY DUTY CONTACT PRESSURE GAUGES WITH BOURDON TUBE AND MAGNETIC SNAP-ACTION CONTACTS OR INDUCTIVE ALARM CONTACTS acc. to EN 837-1



Diameter 100
Connection position radial bottom
or eccentric back
with or without damping



Contact pressure gauges with electrical alarm contacts are suitable for controlling or regulating process sequences. The contacts open or close electrical circuits in relation to the position of the pointer on the pressure gauge. Suitable for media, do not attack the copper alloys, are not highly viscous and not to the crystallize tend.

Type	6001	7911	6111	8011	Options
Diameter	100				
Symbol					
Liquid filling		Silicone oil		Silikon oil	Esteroil (silicone-free)
Numbers of contacts	from 1 bar each 2 magnetic snap-action or inductive alarm contacts, at 1,6 bar 2 magnetic snap-action or 3 inductive contacts from 4 bar 4 magnetic snap-action contacts				
Cable connection	PG 13,5,				
Accuracy class	<= 1,6 bar: cl.1,6; > 1,6 bar: cl.1,0 acc. to EN 837-1				
Ranges	0...1 up to 0...1000 bar negative or positive / negative and positive overpressure				MPa, kPa
Application	Constant load: up to end of scale value Alternating load: up to 0,9-x end of scale value kurzzeitig: 1,3-x overload capacity				
Case / ring	Stainless steel, 1.4301				
Window	Plastic, Polycarbonat				
Dial	Al white, scale and printing black				Dual scale
Pointer	Al black				
Movement	CuZn-alloy				
Measuring element	Cu-alloy up to 40 bar, above 40 bar stainless steel				
Pressure connection	CuZn-alloy				
Connection position	radial bottom		eccentric back		
Thread	G 1/2 B, M20x1,5				others in request
Temperatures	Medium: -20°C up to 80°C, ambient: -25°C up to 60°C				
Temperature drift	0,3%/10K deviation of normal temperature 20°C				
Protection	IP 54	IP 65	IP 54	IP 65	
Orifice					Ø 0,3; Ø 0,4; Ø 0,8
Approx. Weight	0,9 kg	1,2 kg	0,9 kg	1,2 kg	

Electrical details: see special page chapter 6!

Type	Dimensions in mm									
	NG	a	b	b1	D	G	h	M	n	SW
6001/7911	100	15	78	-	100	G 1/2 B	88	88	88	22
6111/8011	100	-	78	113	100	G 1/ B	-	88	88	22

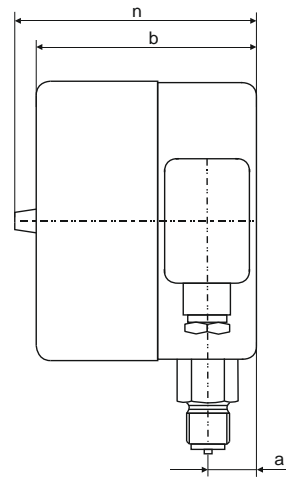
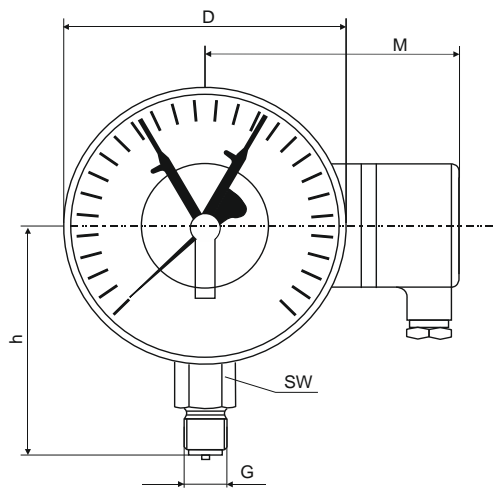

Type 6001/7911

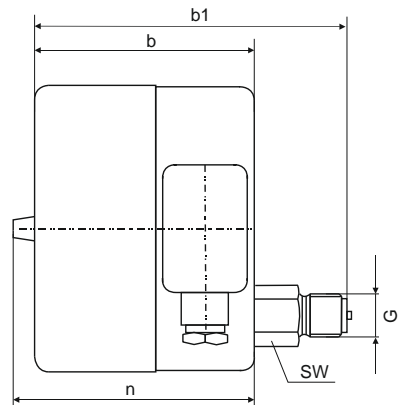
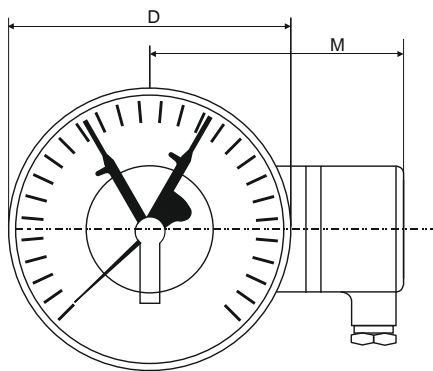

Type 6111/8011

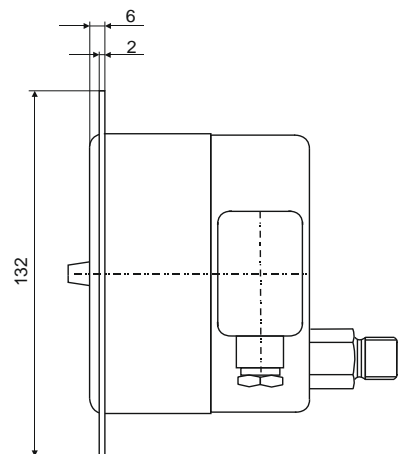
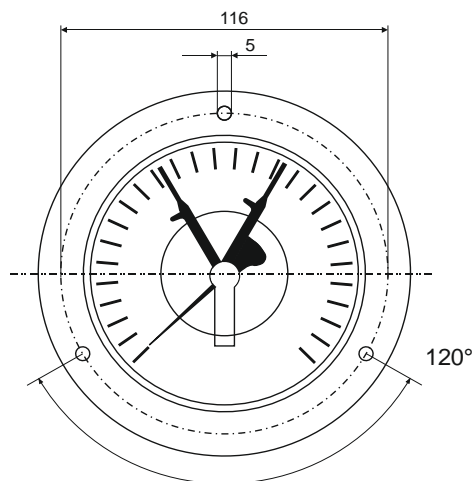

Front flange Type 6111/8011